

Product Manual

BRW1H Range

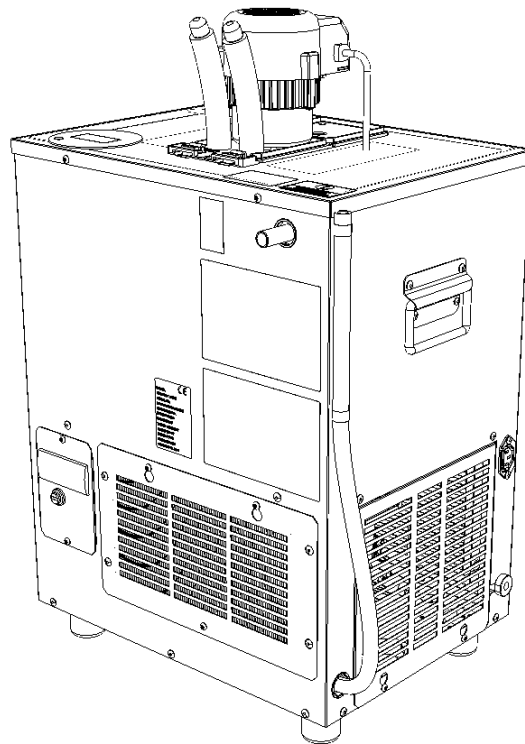

Introduction

Contents

Section	Page	Section	Page
Introduction & Safety	2	Schematics	5-8
Specification & Installation	3	Fault Finding	9
Model Numbering	4	Replacement parts, Removal, Transportation and Disposal	10-11

Introduction

The BRW1H models are a range python temperature cooling units with various control options of variable mechanical, digital and energy saving digital thermostats. The individual modules are detailed later on in this guide, but in summary they comprise the following:

- Base unit
- Control module: a range of control modules with both electronic and variable mechanical thermostat options.
- Pump: Choice of either a 3 stage or 4 stage pump assembly
- Option for unit to be wall mounted on the brackets provided or floor mounted on rubber feet.

The wiring schematics included in the following pages reflect this modularity.



Safety

The BRW1H models use a R290 (Care 40, Propane) refrigerant. Below are some safety points which the end user must adopt to mitigate the risk of unsafe conditions arising.

- Service must only be carried out by a suitably qualified refrigeration engineer.
- The unit must be isolated from the electricity supply before removal of the covers.
- Do not damage the refrigeration circuit.
- Ventilation openings must be clear of obstructions.
- There must be a gap of at least 100mm between the appliance and a wall or other restriction.
- Where electrical components are replaced, the new component must be of the same type.
- Operate the unit within (ambient) operating temperatures; 10°C to 32°C.

Specification and Installation

BRW1H Specification

Dimensions (approx)	Width 451mm	Compressor	Huyai (Cubigel)
	Depth 371mm		NLY45RA
	Height 730mm	Refrigerant	R290
		Refrigerant Weight	70g
Dry Weight	Nominal 28.8Kg	Climatic Class	SN (+10°C to +32°C)
Wet Weight	Nominal 40.0Kg	Nominal Ice Bank	N/A
Supply	230Vac/50Hz	IP Rating	N/A
Rated input	485W	This product contains Propane Refrigerant gas with a GWP of 3 in a hermetically sealed system	
Rated Current	2.3A		
Fuse Rating	5A		

Installation

The unit must be installed by a competent person. If unit is to be free standing, it must be placed on a firm level surface capable of supporting the weight of the machine when the bath is filled. If the unit is to be wall mounted, then please follow the wall mounting instruction provided with the unit. It is important that the ventilation openings in the machine are not blocked to allow the free movement of air. Inadequate ventilation will shorten the life of the fridge system.

Note: At this stage do not connect the unit to the electrical supply

- Ensure that the ventilation openings are not blocked to allow free movement of air through the unit. **Failure to do this will seriously affect the reliability of the fridge, invalidate the warranty and shorten the life of the fridge system.**
- Locate a container beneath the bath overflow to prevent any water spillage as the bath is filled.
- Fill the bath using cold water through the 'Bath Fill' opening on the top of the machine until water is displaced from the overflow.
- Connect the dispense python to the 'Recirculation' Flow and Return.
- Connect the unit to the electrical supply and turn on.
- After a short delay the compressor and fans will start.
- The unit will now begin to reduce the bath water temperature.
- Once the water has been chilled to the correct temperature, the fan and compressor will switch off and the machine is ready for use.

Note: The time taken for the unit to reach operating temperature will vary depending on ambient temperature, humidity and the temperature of the incoming water supply.

Model Numbering

Unit Number (BRW1H) (Y) (Z)

Key:

BRW1H Base Type

(Y) Module Type

(Z) Pump Type

Reference (Y)	Part #	Description
A	1A6384	ELIWELL
Z	1A6385	DFX
S	1A6424	VARIABLE MECHANICAL STAT

Reference (Z)	Part #	Description
SPC43 (3)	1A6394	3 STAGE PUMP ASSY
SPC44 (4)	1A6426	4 STAGE PUMP ASSY

Schematics

BRW1H BASE Wiring Schematic

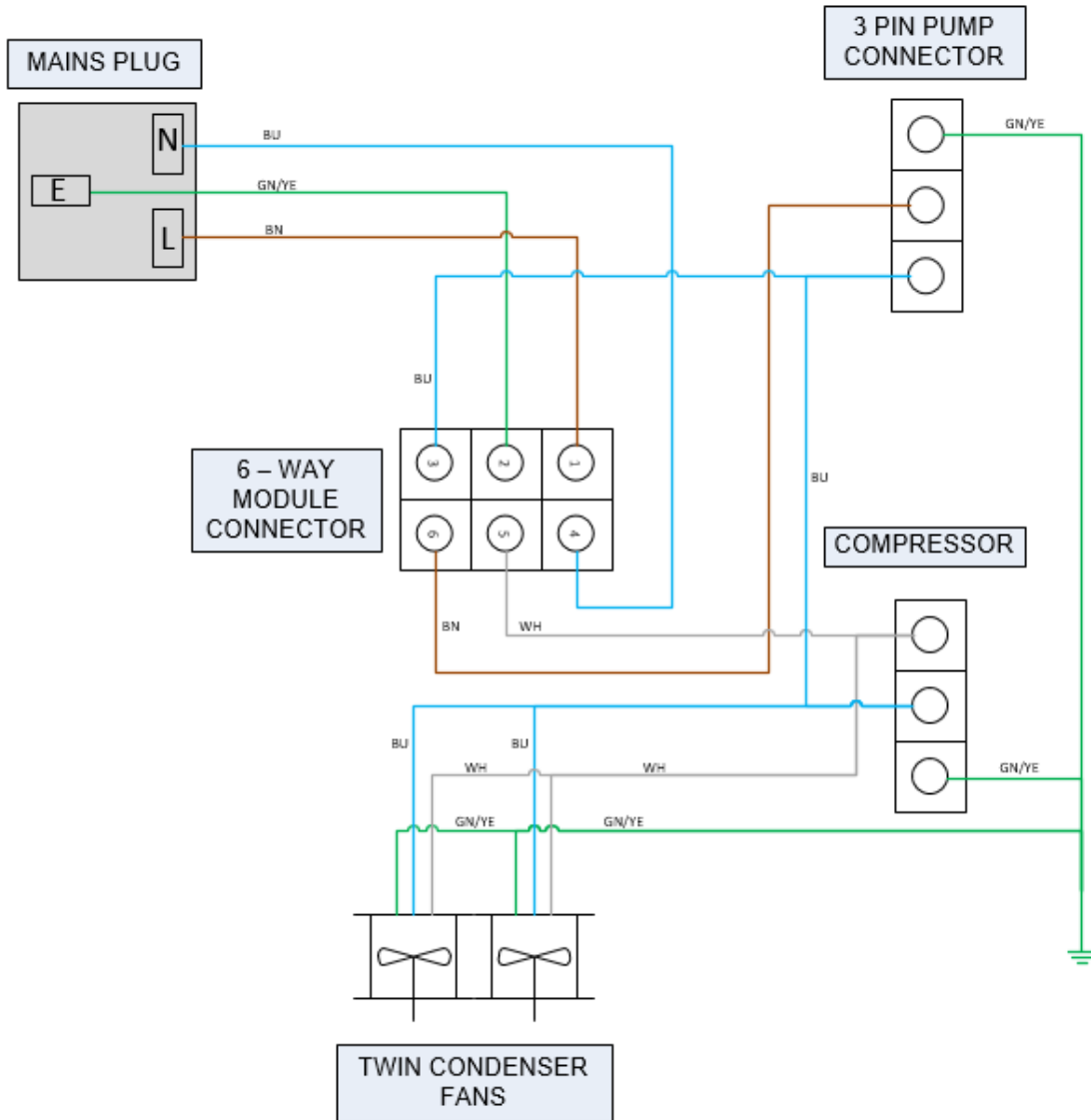

Schematics

BRW1H ELIWELL MODULE WIRING SCHEMATIC

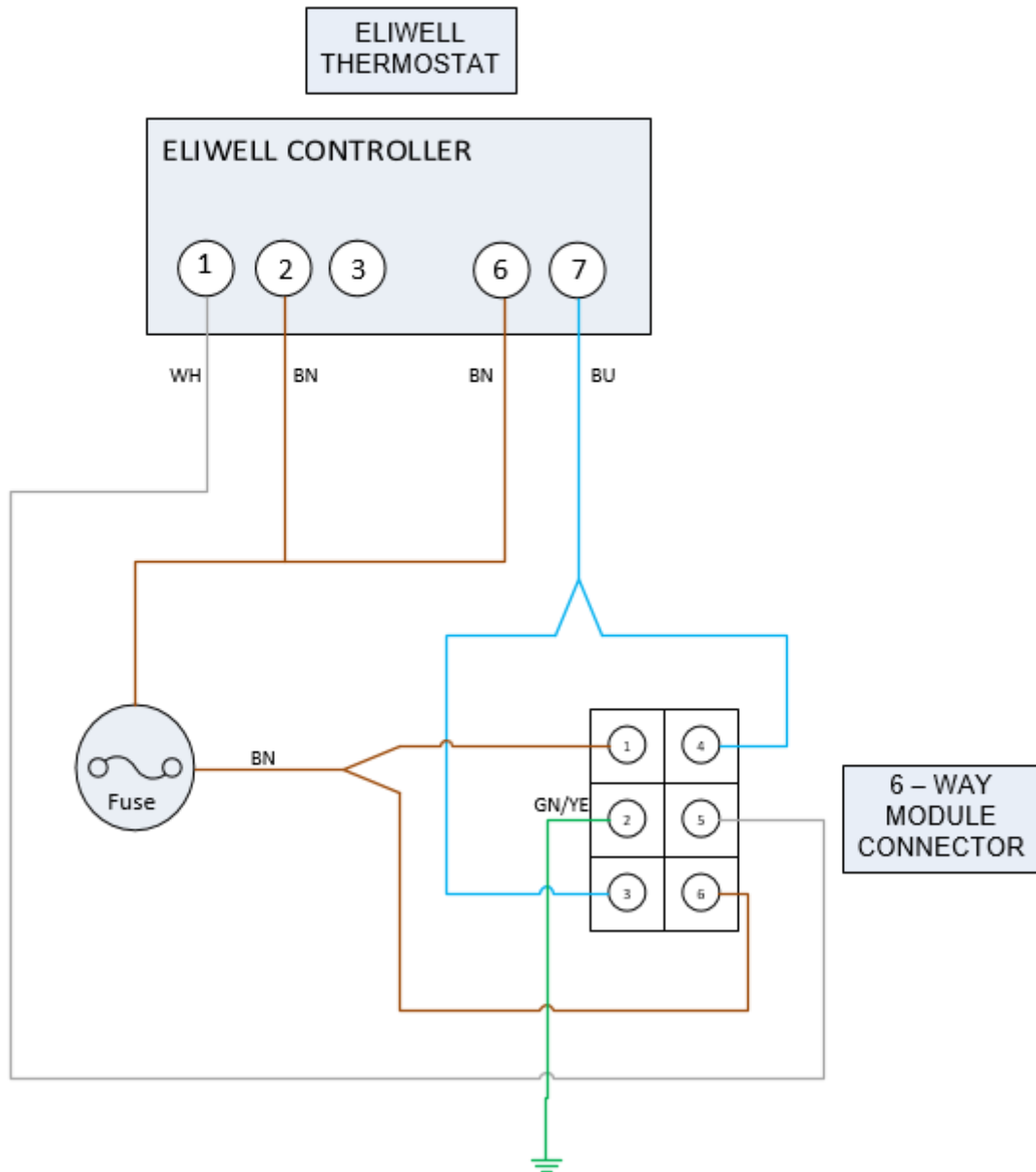

BRW1H
VARIABLE MECHANICAL MODULE
WIRING SCHEMATIC

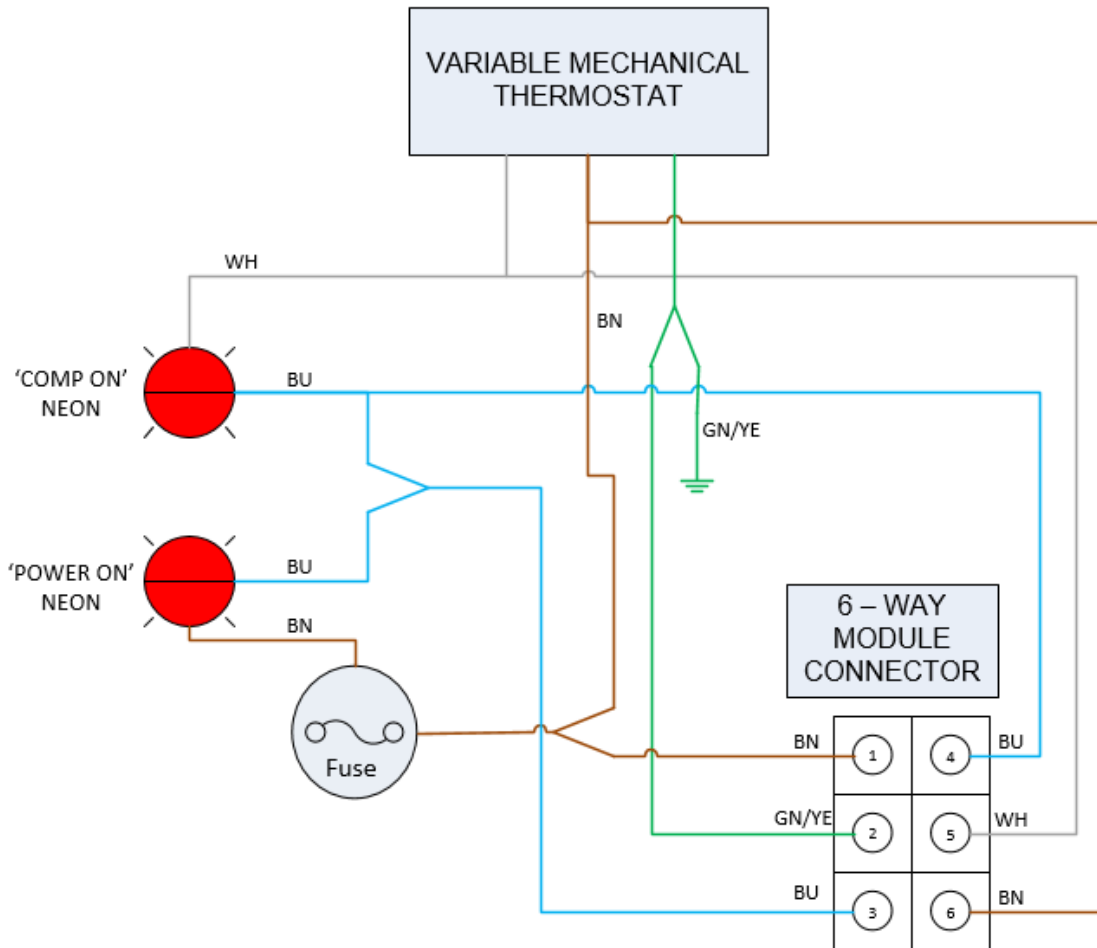

Schematics

BRW1H DFX MODULE WIRING SCHEMATIC

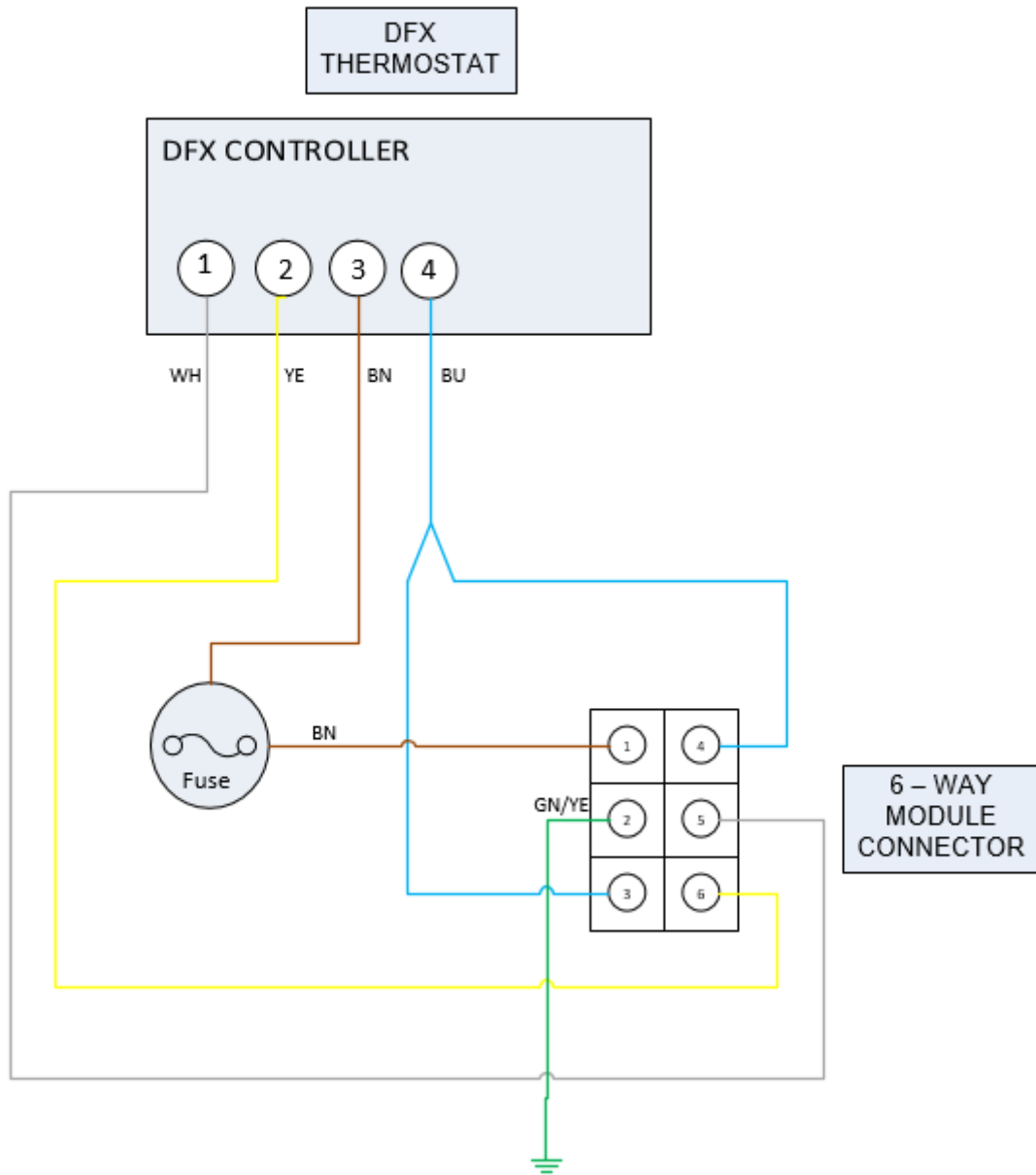

Fault Finding

Prior to any fault finding, please ensure all connections to the chiller are sound and that the incoming supply is turned on. Ensure that all electrical connections to the chiller and in the chiller are secure and in good condition, the power is on and that the chiller has had adequate time to reach operating temperature.

Warm Drinks	Insufficient airflow through the fridge.	Check that the condenser is not blocked. Check for blockages and obstructions to ventilation grills.
	Cooling Fan Not running	Check supply to cooling fan motor. If supply present replace fan motor. If supply not present check connections, thermostat, high side protection (model dependent) and fuse.
	Compressor not running	Check supply to Compressor. If supply present return for repair. If supply not present check connections, thermostat, high side protection (model dependent) and fuse.
	Fridge failure	If compressor & fan are running and there is no cooling, return for repair.

Replacement Parts, Removal, Transportation and Disposal

Replacement Parts

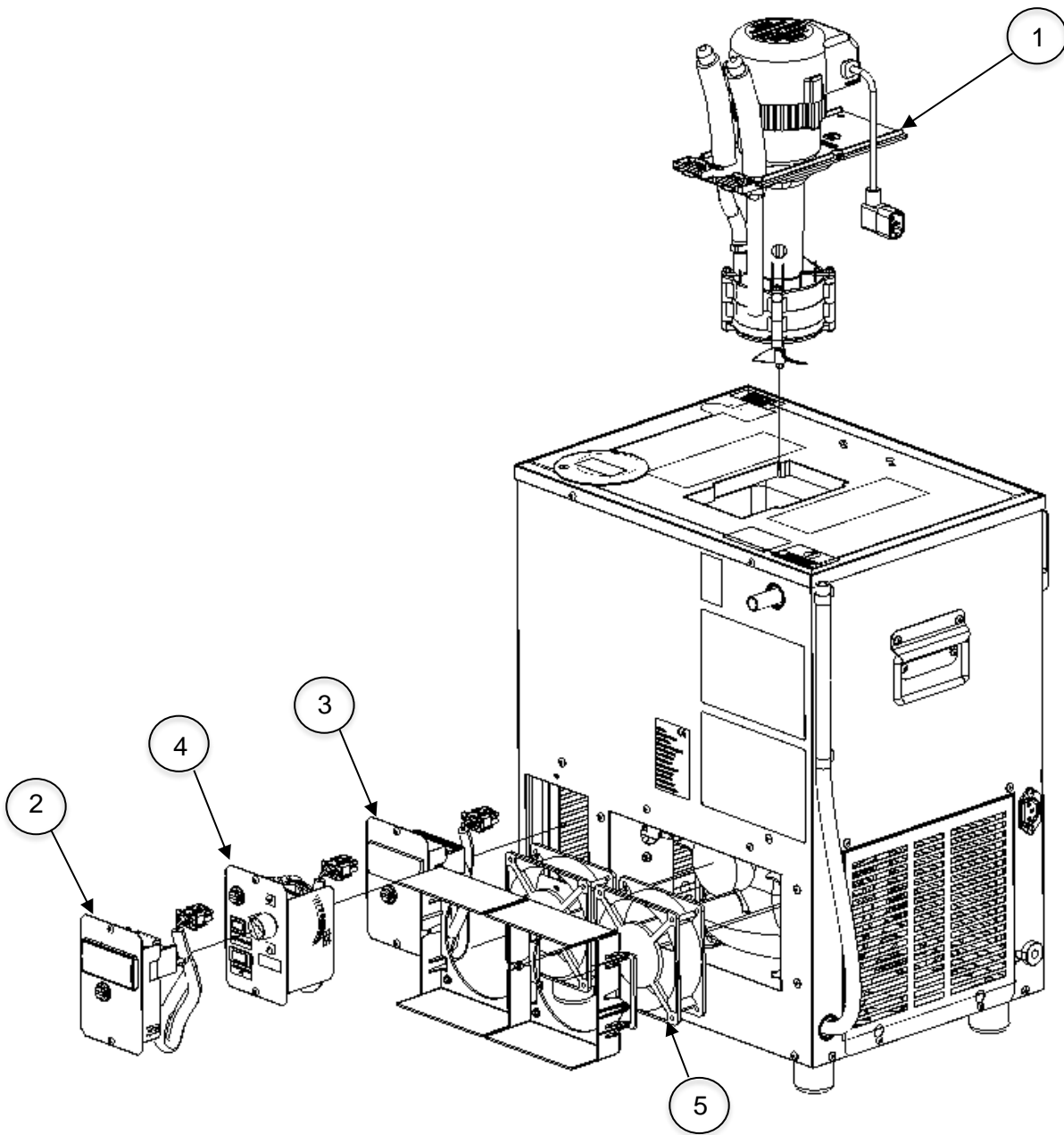

Item No	Replacement Parts	Part No's
1	Pump	See table (Ref Z) on page 4
2	Eliwell Control Eliwell 1.5m probe	3B3472 3B4341
3	DFx Control DFx Probe	3B5544 3B5545
4	Variable Mech Thermostat	1A4247
5	Axial Fan	1B5514

Replacement Parts, Removal, Transportation and Disposal

Removal, Transportation and Disposal

Important: Before removal from the installation, ensure all electrical, product and gas connections are disconnected.

Disposal of Scrap Units

It is illegal to simply scrap a refrigeration unit. Before a unit can be scrapped it must first have the gas removed by a specialist using special equipment. Please contact Booth Dispensers Ltd., who will be happy to provide a quotation for disposal.

Transportation

Important: This unit must be transported in an upright position

As with all refrigeration systems, irreparable damage can be caused by laying the unit on its side or even transporting upside down. Where the unit is transported by a carrier, the carton should always be marked in a conspicuous manner, the correct upright position in which it must be handled.

If a unit has been transported incorrectly it should be placed in the correct upright position and left for 24 hours before attempting to run the system.

Failure to observe the above precautions could seriously damage the system, and would void any warranty. Terms and conditions apply.

Booth Dispensers Ltd, Moor Park Avenue, Blackpool,
Lancashire, FY2 0LZ, UK
+44 1253 501800
<http://www.booth-dispensers.co.uk/>

